

## Reliance Cylinder Head Gaskets for Iveco NEF Engines

Reliance offers two different thickness cylinder head gaskets for the Iveco NEF engines; 1.15mm and a 1.25mm thick. The option exists to maintain favorable compression characteristics and minimize “dead space” on engines regardless piston protrusion, the result being improved overall efficiency of the engine.

The following procedure will help you find the correct head gasket for your engine;

Piston Protrusion Spec – 0.28mm – 0.52mm

Measure the protrusion of each piston on each side at 45mm from the center of the piston directly over the pin (Fig 1). Add those two measurements together and divide by two to find the average piston protrusion for each cylinder. Add all six of those averages and divide by six to find the overall average piston protrusion for the engine. If it is less than 0.40mm use the 1.15mm thick gasket. If it is 0.40mm or greater, use the 1.25mm thick gasket.

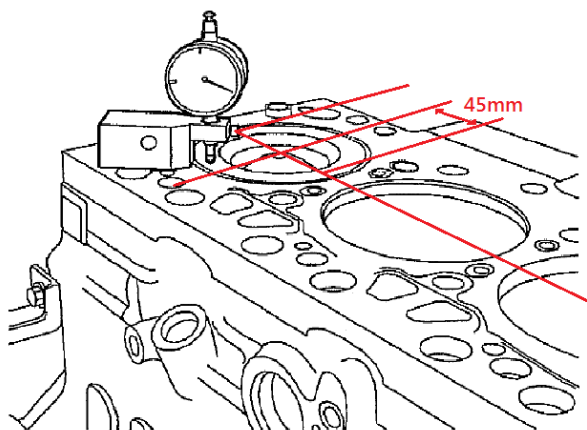

Figure 1

Part Number	Engine Application	Gasket Thickness
112830920	4 Cyl NEF	1.15mm
112830919	4 Cyl NEF	1.25mm
112830923	6 Cyl NEF	1.15mm
112830922	6 Cyl NEF	1.25mm